

# Neosentience and the Abstraction of Abstraction

Bill Seaman

*Department of Art, Art History & Visual Studies, Duke University, 114b East Duke Building Box 90764, Durham NC, USA, [bill.seaman@duke.edu](mailto:bill.seaman@duke.edu), +1919 937 4342*

**Abstract:** This paper employs a survey methodology to point at notions surrounding “the reflexive” and “reciprocity” drawn from the history of Cybernetics as it falls in relation to current “Neosentient” research. Seaman and O. E. Rössler have been involved in a decade long discussion exploring the future of artificial intelligence and its relation to robotics. Seaman coined the term Neosentience arising out of this ongoing “conversation” with Rössler which is articulated in their book – **Neosentience | The Benevolence Engine** (Seaman & Rössler, 2011). The book is a non-linear compendium of observations. When we abstract thought potentials in the human and seek to re-embodiment them within a robotic system in a functional manner that reflects the original bio-functionality of the human, we are thus elucidating the abstraction of abstraction.

**Keywords:** Neosentience; bisociation; neosentient design; artificial Intelligence; robotics; multi-perspective approach; 2<sup>nd</sup> order Cybernetics; insight engine

**Acknowledgement:** I would like to thank the department of Art, Art History & Visual Studies, Duke University for supporting Neosentience Research and the attendance of this conference.

This article is available from <http://www.systems-journal.eu>

© the author(s), publisher and licensee

Bertalanffy Center for the Study of Systems Science <http://www.bcscs.org>

This is an open access article licensed under the [Creative Commons Attribution 3.0 Austria License](https://creativecommons.org/licenses/by/3.0/). Unrestricted use is permitted provided the original work is properly cited.



Seaman and O. E. Rössler have been involved in a decade long discussion exploring the future of artificial intelligence and its relation to robotics. Seaman coined the term Neosentience arising out of an ongoing “conversation” with Rössler which is articulated in their book – Neosentience | The Benevolence Engine (Seaman & Rössler, 2011). We consider a Neosentient robotic entity to be a learning system that could exhibit well-defined functionalities: It learns; it intelligently navigates; it interacts via natural language; it generates simulations of behavior (it “thinks” about potential behaviors) before acting in physical space; it is creative in some manner; it comes to have a deep situated knowledge of context through multimodal sensing; it exhibits a sense of play; it will be mirror competent and will in this sense show self-awareness; It will be competent to go through the personogenetic bifurcation (thereby acquiring the ability to articulate meta-levels and meta-patterns). We have entitled this robotic entity The Benevolence Engine. The interfunctionality is complex enough to operationally mimic human sentience. Benevolence can in principle arise in the interaction of two such systems. (Seaman & Rössler, 2011) Each of these “pragmatic” benchmarks (as distinct from the Turing Test) (Turing, 1950) (Stanford Encyclopaedia of Philosophy) will be discussed in relation to earlier cybernetic research. The Neosentient will be brought up (brought to life) in a social and cultural sphere of reciprocal inter and intra-actions contributing to language and knowledge acquisition. This is achieved thought embodied relations to the environment, self and others.

## 1 Neosentience and its relationality to Cybernetics and the Biological Computer Laboratory

There are two basic approaches to the exploration of Neosentience

- The creation of such a machine via the embodiment of a series of specific algorithms on a parallel computing platform working in conjunction with a specific situated machinic sensing environment and robot.
- The development of a new paradigm for computing through the generation of an Electrochemical Computer functioning in conjunction with a robot and a related sensing system.

Such questions as how do we Abstract Abstraction; how can such a system employ informed “reciprocity” – mutual exchanges and relational intra-actions as a central aspect of our and its “coming to be”? In particular one central question is how can we embody the reciprocal nature of human benevolence in the Neosentient — How can the system be optimized such that “A is better off if B is better off” in the words of von Foerster? (Foerster, 1981) Glanville suggests that Cybernetics has always been an abstraction, pointing to Ashby’s comment “cybernetics is the study of all possible abstract machines.” (Glanville, 2012) It must be noted that since the time of Biological Computer Laboratory, 1958-1976 (Müller, 2000), many different forms of research have been undertaken. Yet, most of these have produced stand-alone systems with specific functionalities. It will be the enfolding of these different approaches and functionalities that will finally contribute to the creation of a robot that is autonomous in nature. Yet, it is always of interest to me as a researcher to point to the moment of inception for particular ideas and research paradigms. The Biological Computer Laboratory and the Cyberneticists that brought it to life are central in this light. For

Neosentience research the goal is to understand the human to the greatest extent possible. This is self-reflection on the highest level, being undertaken as a continuous process --- an ongoing “chipping away” at the hardest of questions from multiple disciplinary perspectives that are being brought into dynamic relation. In 2006 Rössler and Seaman produced a flow chart of the salient functionalities at operation in the Benevolence Engine. This diagram included a series of internal loops.

## 1.1 The overarching components of the system

Polysensing system for multi-modal machinic sensing; B) Buffer / Pattern Matching; C) “Big Screen” metaphor – Real-time production of multi-modal VR; D) Force Field Generator (attraction and repulsion) forming synthetic emotions; E) Joystick metaphor (navigation in real and imagined space); F) Overlap Buffer – the ability to think about action (simulate) before performing it; G) Efference (copy)/re-afference H) Motors / Affector Potentials; and I) Long-term memory. The functionality of this system is described at length in *Neosentience | The Benevolence Engine* (Seaman & Rössler, 2011).

The Benevolence Engine - Bill Seaman and Otto Rössler c2006

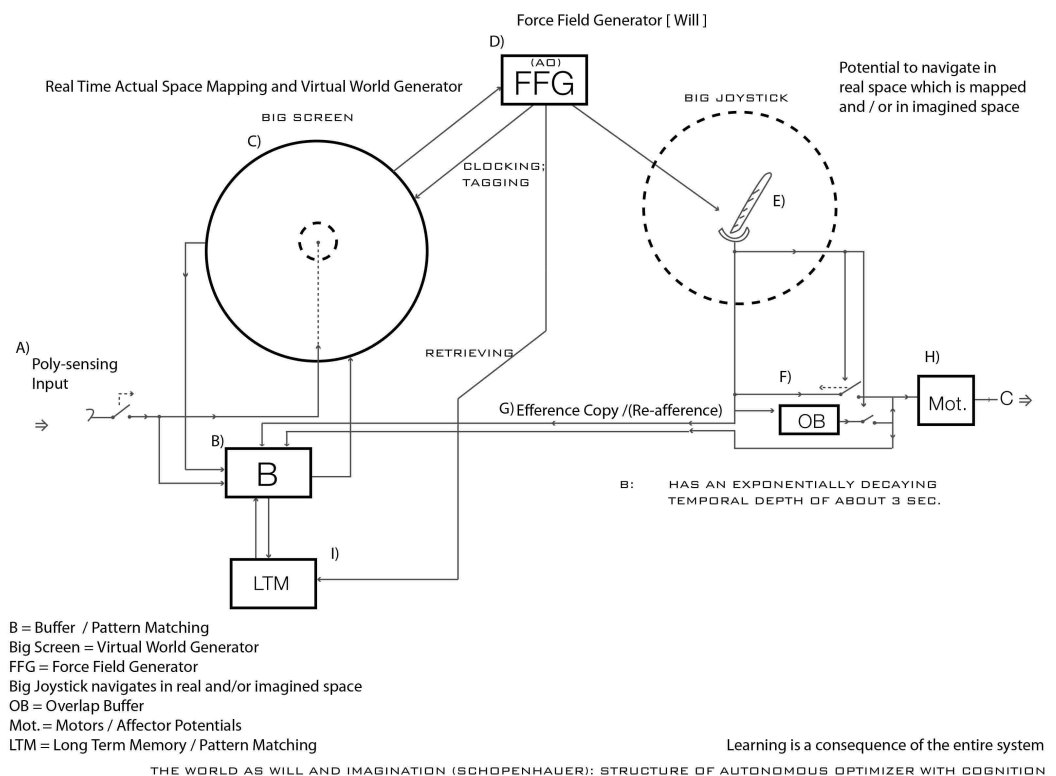

Figure 1

## 1.2 Patterns and Neosentience

In the articulation of Neosentience it has become clear that many different qualities of patterns come together in the service of the functionality of the system. Thus, a multi-perspective approach to knowledge production in the service of Neosentient Design is currently undertaken, “Design as every linguistic functionality” [Glanville] is explored (Glanville, 2007). Additionally multiple foci from Understanding Understanding (Foerster, 2003), a central von Foersterism becomes enfolded in our research into Neosentient Design and the abstraction of abstraction. The notion of patterns and pattern recognition here



is central. Seaman and Rössler discussed many varieties of pattern in their book including: Pattern Recognition; Patterns of patterns / meta patterns; Pattern topologies; Pattern sensing; Pattern orientation; Pattern comparison; Pattern abstraction; Pattern imagination; Pattern recombination; Pattern generation (fragment collages); Pattern gestalts; Pattern projection (intermingling with environment); Pattern confluence; Pattern transference (technological production); Pattern implementation; Pattern re-orientation (categorization); Pattern strings; Pattern fields; Pattern actions (spatial / conceptual / relational); Pattern navigation; Pattern recognition; Pattern truncation; Pattern abbreviation; Pattern inversion; Pattern mistreatment; and Pattern realignment. Enfolding new approaches to the articulation and abstraction of patterns of different kinds is central to Neosentience. Seaman's text *Pattern Flows | Hybrid Accretive Processes Informing Identity Construction* (Seaman, 2005) points toward a multi-modal approach to learning and language acquisition. Central to the history of Cybernetics is the study of patterns. (Zhuravlev & Gurevich, 2010)

### 1.3 Pask and Neosentience – multiple relationalities

Such an embodied approach to language/knowledge acquisition was fully understood by members of the BCL. Pask in *An Approach to Cybernetics* states:

*Cybernetics' "... interdisciplinary character emerges when it considers economy not as an economist, biology not as a biologist, engines not as an engineer. In each case its theme remains the same, namely, how systems regulate themselves, reproduce themselves, evolve and learn. Its high spot is the question of how they organize themselves." (Pask, 1961)*

Pask was also keen to reverse engineer and abstract the biological processes that enable thought. His explorations of electrochemical processes, were certainly one precursor to the interest in constructing a "contemporary" functioning electrochemical computer. His texts concerning "Chemical Computers", in *An approach to Cybernetics*, where he states "chemical computers arise from the possibility of growing in an active evolutionary network by an Electrochemical process." were pivotal. (Pask, 1961) He also pointed to MacKay as another experimenter in this realm.

*"D. M. MacKay has used the same process for producing 'analogue connective elements' in a computing machine." (Pask, 1961, p.105)*

### 1.4 Observing Systems - Neosentience, complexity and linguistic aspects of the Insight Engine

As we study the body/brain/mind/environment set of relations in terms of all of the biological processes that are relevant in terms of thought productions, we find a world of ultra-complexity. It became apparent that creating a digital tool to function as a "midwife" to such research processes, was essential. Seaman is currently working on the development of an "Insight Engine" (Funded by the Duke Institute for Brain Sciences) to function in the service of Neosentient research. The object is to employ human input; collaboration across fields; interactivity; computational mapping of data; the elucidation of entailment structures; a multimodal approach to media; computational linguistics; real time creation of ontologies; active intelligent agents; and the creation of an index of operative relationalities; as a means to help elucidate approaches to biomimetics and bio-abstraction germane to knowledge production surrounding Neosentience research. One area of interest is linguistic framing



and titling that enables complex ideas that are “reflexive” to become embodied and shared. Linguistic frames and jargon shift across research domains. How can we design new context-aware systems that enable relevant jargon translation and use in interdisciplinary and transdisciplinary research and in turn, Neosentient design? We are “Observing Systems” – a lovely bidirectional articulation by von Foerster. A number of foci of relevance here were first articulated by von Foerster in *Observing Systems* (Foerster, 1981). We note the playful embodiment of reflexivity and polysemy in this title and other titles of von Foerster.

### 1.5 Neosentience – Cybernetics, abstraction and human | computer relationality

Thus the project of Neosentience is highly paradoxical – one must continue to come to know the human at the highest level to begin to abstract human functionality into a machine. The human is already a computer, an ultra-abstract machine. Cognition, as von Foerster states = computations of computations. (Foerster, 1981) The study of Neosentience explores such issues as Science ↔ Art relationalities (Perriquet & Seaman, 2011), important to both Pask and von Foerster (Pickering, 2010; Glanville, 2011; Foerster, 1974) as part of a multi-perspective approach to knowledge production. How do we abstract the ability to become meta-observers? How do we abstract meta-operations across differing research domains? In particular how can we become meta-creative, exploring the creation of creativity algorithmically, and/or bio-algorithmically (Seaman & Rössler discussion) as it is actually played out in an electrochemical substrate? How do we best reverse engineer our creative natures? The defining of a dynamic relationality across many research fields is a highly important concept to both Cybernetics and Neosentient study. In a discussion with Albert Müller, he pointed to the notion that in second order cybernetics, the entire space is considered as one system. In particular, cybernetic notions surrounding abstraction are central to Neosentient design. (Foerster, 2003; Müller, 2005; Pask, 1958)

### 1.6 Neosentience – Second Order Cybernetics and the notion of Open Order Cybernetics

Above we have begun to elucidate what second-order cybernetics has contributed to Neosentience research. In keeping with the circular/spiral nature of cybernetic systems, we will, reflexively, ask the same question in reciprocation: what have the various fields brought to second-order cybernetics? (Glanville, 2011) Seaman and Gaugusch in a paper entitled in *(Re)Sensing the Observer*, call for an “Open Order Cybernetics” (Gaugusch & Seaman, 2004), exploring the open field of growth that language and technology suggest for the human. *Open Order Cybernetics*, continues to grow infinitely as it re-defines itself both linguistically (self-definition) and technologically [remembering language is also a technology – See Seaman’s World Generator System – and *Recombinant Poetics | Emergent Meaning in a Specific Generative Virtual Environment* (Seaman, 2010) originally 1999]. This form of ongoing technological growth, as it alters the functioning of the human exhibits a form of abstracted and/or augmented-autopoeisis (Maturana & Varela, 1980) - e.g. via technological systems that take the place of biological functionalities. “Open Order Cybernetics” also expands as a new form of observer comes into the picture – Neosentient entities (Seaman, 2008). We must also point to cyborgian technological potentials as well as new potentials for computational linguistic “creativity” and “bisociation” Koestler, 1964) informing our “open order” approach. In particular the potentials of bisociation are being explored in Seaman’s



*Insight Engine* (Seaman, 2011). Glanville in conversation with Seaman suggested that Second Order Cybernetics already exhibits such an open order perspective, which may well be the case, enfolding each new linguistic perspectives and human/autonomous machine relationality as part of observing Observing Systems. (von Foerster, 1974; von Foerster, 1981) Seaman believes that Neosentient computational observers will potentially “Open” out this field.

## 2 The body as electrochemical computer<sup>1</sup> – cybernetic precursors

How can we articulate new forms of computation inspired by differing computational functionalities found in the body— currently non-entailed bio-algorithms? (Seaman, 2012) What are the Cybernetic precursors that become enfolded to inform this research? Perhaps the beginning of research leading to the possibility of creating an electrochemical computer of the continuous variety, and a pre-cursor to later research in cybernetics by Pask and others, was presented in a text by N. Rashevsky, (Pitts’ teacher) in 1933. This text foreshadowed many of the ideas that become abstracted in the McCulloch and Pitts paper of 1943 titled “A logical calculus of the ideas immanent in nervous activity”. Rashevsky wrote “Outline of a Physico-mathematical Theory of Excitation and Inhibition” (received for publication March 18, 1933). In it he states,

*“The aim of this present paper is to present a phenomenological theory, which however is susceptible of a simple physical interpretation. It is not an attempt to merely add another possible expression to the great number of already existing ones, but to introduce what seems to us to be an essentially new point of view. This new point of view appears to give a rather simple explanation of many important phenomena of excitation and inhibition.”*

He went on to say:

*“The fundamental assumption is made, that every nerve contains two antagonistic substances (or groups of substances), one exciting and the other inhibiting. It is assumed, that an electric current passing through the nerve is supposed to happen whenever the ratio of the concentrations of exciting and inhibiting substances exceed at that place a critical value.”*

Here, Rashevsky was already pointing to the fact that multiple processes were at operation contributing to the efficacy of the neuron. Rashevsky is often left out of the lineage related to parallel computing. Author Daniel S. Levine in his book *Continuous and Random Net Approaches an Introduction to Neural and Cognitive Modeling* (Levine, 2009) suggests that “While the cybernetic revolution was simulating discrete (digital) models of intelligent behavior, there was a concurrent proliferation of results from both experimental neurophysiology and psychology. Some of these experimental results stimulated the development of continuous (analogue) neural models...One of the pioneers in the development of continuous neural models was Rashevsky. The best exposition of his

---

<sup>1</sup> For a detailed discussion of the electrochemical computer and additional aspects of the insight engine see – (Re)Thinking — The Body, Generative Tools and Computational Articulation. (Seaman, 2010)

outlook was in his 1960 book, *Mathematical Biophysics*. The first edition of this book had been written in 1938— 5 years before the seminal article of McCulloch and Pitts. Subsequently, the evolution of Rashevsky's thinking had been altered by the McCulloch and Pitts article (which was published in a journal that Rashevsky himself founded and edited)...” (Levine, 2009, p27)

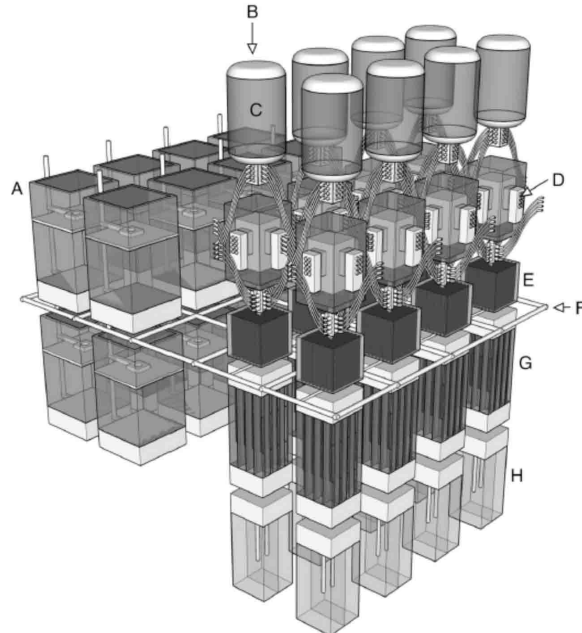

Figure 2: Figure showing one possible arrangement of modules within our initial electrochemical computer concept. Concept by Bill Seaman and Tim Senior. Image by Tim Senior. Figure showing one possible arrangement of modules within our initial electrochemical computer concept. A, Electrochemical oscillator unit; B, Module column; C, Neurotransmitter (NT) analogue; D, Site of control for NT analogue release; E, Processor – input integrator; F, Routes for direct external inputs; G, Electrochemical memory element; H, Electrochemical modulator unit used to drive either excitatory or inhibitory changes within modules from transduced external sources.

Figure 2: Initial Rendering of a Concept for an Electrochemical Computer by Bill Seaman and Tim Senior. The system would include a Polysensing environment and transduction methodology as well as a transducing output system.

## 2.1 Neosentience - analogue and digital approaches and the “psycho-physical parallelism”

Another scientist observing human computation for the purposes of abstraction was von Neumann. von Neumann often attended the Macy Conferences (starting in 1949), a highly transdisciplinary gathering of cyberneticists. Von Neumann put his ideas in very clear form related to biology, the body and thought:

*“[...] it is a fundamental requirement of the scientific viewpoint the so-called principle of the psycho-physical parallelism – that it must be possible so to describe the extra-physical process of the subjective perception as if it were in reality in the physical world – i.e., to assign to its parts equivalent physical processes in the objective environment, in ordinary space.” (1948)*

In terms of Abstracting Abstraction he took on a pragmatic approach through a specific axiomatic procedure:

*“Axiomatizing the behavior of the elements means this: We assume that the elements have certain well-defined, outside, functional characteristics; that is, they are to be*



*treated as “black boxes.” They are viewed as automatisms, the inner structure of which need not be disclosed, but which are assumed to react to certain unambiguously defined stimuli, by certain unambiguously defined responses. This being understood, we may then investigate the larger organisms that can be built up from these elements, their structure, their functioning, the connections between the elements, and the general theoretical regularities that may be detectable in the complex syntheses of the organisms in question.” (von Neumann, 1995)*

Von Neumann early on saw the mixed character of the living organism.

*“When the central nervous system is examined, elements of both procedures, digital and analog, are discernible...Thus a digital element is evidently present but it is equally evident that this is not the entire story. A great deal of what goes on in the organism is not mediated in this manner, but is dependent on the general chemical composition of the blood stream or of other humoral media. It is well known that there are various composite functional sequences in the organism which have to go through a variety of steps from the original stimulus to the ultimate effect – some of the steps being neural, that is, digital, and others humoral, that is, analogy. These digital and analogy portions in such a chain may alternately multiply. In certain cases of this type, the chain can actually feed back into itself, that is, its ultimate output may again stimulate its original input.” (von Neumann, 1995, pp. 534–35.)*

## 2.2 Neosentience, Cybernetics and feedback loops

The importance of feedback loops are of great importance to Neosentience production.

Naumann discussed this in relation to humoral and neural media:

*“It is well known that such mixed (part neural and part humoral) feedback chains can produce processes of great importance... The living organisms are very complex – part digital and part analogy mechanisms. The computing machines, at least in their recent forms to which I am referring in this discussion, are purely digital. Thus I must ask you to accept this oversimplification of the system. Although I am well aware of the analogy component in living organisms, and it would be absurd to deny its importance, I shall, nevertheless, for the sake of the simpler discussion, disregard that part.” (von Neumann).*

Yet, Seaman believes we need to reflect the deep complexity of the functionality of the body in terms of the design of future computational systems— this might be considered to be bio-algorithmic computation that is not entailed mixing digital and analogue flows.

## 2.3 Neosentience and biomimetics

Von Neumann also seemed to be quite interested in analogue computation but for the sake of alleviating noise, kept computation in the digital arena. He stated:

*“The relevant assertion is, in this respect, that the fully developed nervous impulse, to which all-or-none character can be attributed, is not an elementary phenomenon, but is highly complex. It is a degenerate state of the complicated electrochemical complex which constitutes the neuron, and which in its fully analyzed functioning must be viewed as an analogy machine. Indeed, it is possible to stimulate the neuron in such a way that the breakdown that releases the nervous stimulus will not occur. In this area*



*of “subliminal stimulation,” we find first (that is, for the weakest stimulations) responses which are proportional to the stimulus, and then (at higher, but still subliminal, levels of stimulation) responses which depend on more complicated non-linear laws, but are nevertheless continuously variable and not of the breakdown type. There are also other complex phenomena within and without the subliminal range: fatigue, summation, certain forms of self-oscillation, etc.” (von Neumann, 1995)*

The future of computing is potentially of a mixed analogue and digital nature...or at least abstracts these diverse intra-acting bio-processes in Neuromorphic systems. (Folowosele, 2010) Such a biomimetic course was initiated in the study of Bionics...

*“It was the notion that the processes of communication and control in living organisms (Weiner - Cybernetics) may serve as prototypes for the solution of a large variety of engineering problems...”*

*“A strategy that aims at the synthesis of systems which indeed perform the desired operations must come up with the synthesized system’s structural and functional organization which is at least sufficient to perform the desired task.” (von Foerster, 1965)*

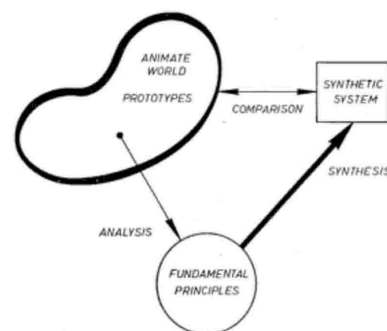

Fig. 1. — Bionics; Methodology and Motivation

Figure 3

Thus, we can study entailment structures and seek to make “analogous” functional substitutions in machinic systems - biomimetics. Sentience is an emergent phenomena that has not yet been fully entailed. As black boxes are replaced with knowledge of articulated functionality then “emergence” is replaced with “entailment”. To my mind, the future of computing is of a mixed analogue and digital nature. Nadin said:

*“Once we reach the threshold of complexity at which causality itself is no longer reducible to determinism, and the condition of the living integrates past, present and future, a new form of adaptive behaviour and of finality (purposiveness) emerges that makes anticipatory processes possible, although only as non-deterministic processes (after all, anticipation is often wrong).” (Nadin, 2010)*

### 3 Abstracting Abstraction through “Understanding Understanding”

How do we Abstract Abstraction? In part by thinking about thinking and in part by *Understanding Understanding*. (von Foerster, 2003). In his paper *Computation in Neural*



Nets, von Foerster early on clearly layed out a set of different abstractions to explore logical operations in neural nets. (von Foerster, 2003)

TABLE 1.















1	2	3	4	5	6	7
#	A B 00 00 00 00	CRISTIAN SYMBOL	NEURAL NET A B B-THRESHOLD	SYMBOLIC LOGIC	NAME	Q
0	00 00 00 00	X	 $\theta=5$	$(A \cdot \bar{A}) \cdot (B \cdot \bar{B})$	CONTRADICTION (ALWAYS FALSE)	4
1	10 00 00 00	X	 $\theta=0$	$\bar{A} \cdot \bar{B}$	NEITHER A NOR B	3
2	00 00 00 00	X	 $\theta=2$	$A \cdot \bar{B}$	A ONLY	3
3	10 00 00 00	X	 $\theta=-1$	$\bar{B}$	NON B.	2
4	00 00 00 00	X	 $\theta=2$	$\bar{A} \cdot B$	B ONLY	3
5	10 00 00 00	X	 $\theta=-1$	$\bar{A}$	NON A	2
6	01 01 00 00	X	FIG. 12 b	$(A \cdot \bar{B}) \cdot (B \cdot \bar{A})$	EITHER A OR B (EXCLUSIVE OR)	2
7	11 00 00 00	X	 $\theta=-1$	$\bar{A} \cdot \bar{B}$	NOT BOTH, A AND B.	1
8	00 00 00 00	X	 $\theta=2$	$A \cdot B$	A AND B.	3
9	10 00 00 00	X	FIG. 12 a	$(A \cdot B) \cdot (\bar{A} \cdot \bar{B})$ $A \neq B$	A IS EQUIVALENT TO B	2
10	01 00 00 00	X	 $\theta=1$	A	A	2
11	10 00 00 00	X	 $\theta=0$	$B \rightarrow A$	B IMPLIES A	1
12	00 00 00 00	X	 $\theta=1$	B	B.	2
13	01 00 00 00	X	 $\theta=0$	$A \rightarrow B$	A IMPLIES B.	1
14	01 01 00 00	X	 $\theta=1$	$A \vee B$	A OR B (INCLUSIVE OR)	1
15	11 00 00 00	X	 $\theta=0$	$(A \vee \bar{A}) \cdot (B \vee \bar{B})$	TAUTOLOGY (ALWAYS TRUE)	0

Figure 4

When we undertake a decision making process we do a “mental simulation” related to the potential future outcomes. In “Perception of the Future and the Future of Perception” from the same book (first given as an address in 1971 but published much later), von Foerster was also interested in thinking about ‘thinking about’ the future. He later discussed this in depth in *Understanding Systems*. Rosen has also discussed *Anticipatory Systems* in his book of the same title. (Rosen, 1985) Nadine discussed the relation between Rosen and von Foerster (Nadine, 2010) “von Foerster himself was aware of Rosen’s work and found the subject of anticipation very close to his own views of the living and on the constructivist Condition of Knowledge. But what prompts our decision to bring up von Foerster is the striking analogy between Rosen’s model (1985a, p. 13) (Figure 5) and von Foerster’s concept of non-trivial machines (von Foerster & Poerksen, 2002) ‘Roadsigns definitions postulates aphorisms, etc.’ [sic] (von Foerster 1995) (Figure 6).

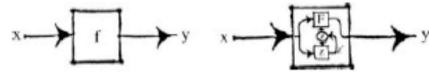

Figure 5

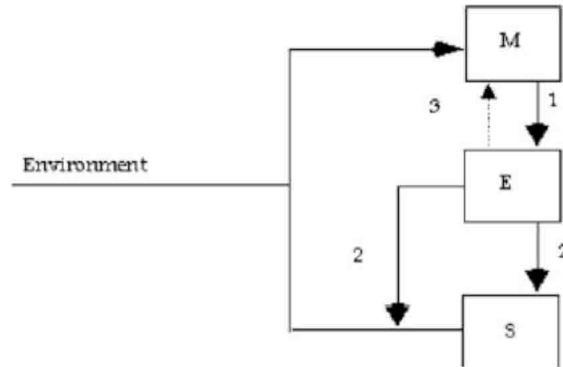

Figure 6

*“Let us only make note of the fact that non-trivial machines are dependent on their own history (which is the case with Model M in Rosen’s model), cannot be analytically determined, and are unpredictable.” (cf. von Foerster & Poerksen 2002, p. 58).*

### 3.1 What computations become involved in abstraction?

What are the various computations at operation in the body that contribute to planning, thought, memory, learning, creativity, play, emotion, and the ability to employ logical processes? How can contemporary understanding related to the breadth of human computation inform new forms of computation exploring both biomimetic and bio-relational approaches. Can some processes only be enabled in an analogue environment?

Givón discusses the problem of reflecting the complexity of human abstraction:

*“...Here lies or first predicament of pragmatics, that of completeness:*

- 1) So long as the system is fully specified, i.e. closed, it must remain in principle incomplete.*
- 2) So long as one is allowed to switch meta-levels — or points of view — in the middle of a description, the description is logically inconsistent.” (Givón, 1989)*

Givón continues — Russell's Constraint on Systems:

*“A self-consistent (though in an obvious sense incomplete) logical description can only operate within a fixed point of view, context, meta-level”... In imposing his constraint, Russell, with one wave of his magic wand, exorcised the spectre of pragmatics out of deductive logic. This exorcism yielded two results, the first intended, the second perhaps not altogether obvious to the exorcist himself at the time:*

- a) Deductive logic was rescued as a closed, internally- consistent, coherent system.*
- b) The instrument of deductive logic was removed, once and for all, as the serious contender for modelling, describing or explaining human language — or mind.” (Givón, 1989)...“Neither language nor mind abides by the requirement of closure, except perhaps temporarily, for limited tasks. Both language and mind are necessarily open*



*systems that continually expand, add meta-levels, learn and modify themselves... “*  
(Givón, 1989)

### 3.2 Biological computations — multi-value logic and physical logic

In terms of developing an analogue logic approach to such processes we can discuss the “M-valued Logic” of Gotthard Gunther developed in part through research at the BCL. (Gunther, 1962). Morphogrammatic Logic is

*“Logic which uses morphograms instead of values as basic operational units might be able to cope with the specific properties of self-coding systems of mind-like or mental character.”*

[Seaman and Rössler call these self-coding systems — non-entailed bio-algorithms]. Gunther goes on to say:

*“The ultimate aim of the cybernetical systems-approach is to design computers as fully self-reflective systems. The theory of resolvable functions suggests that logical relations between individual values do not properly represent the complex characteristics of reflection...This indicates that in order to represent reflection we have to look for a different (and more complex) logical unit. This seems to be the morphogram.”* (Gunther, 1962)

A detailed description of the thought of Gunther is presented by Rudolf Kaehr. In his text *Morphogrammatic And Computational Reflection*. (Kaehr, date not set). Kaehr discusses the consequences of this approach:

*“What still remains of interest for the design of a new paradigm of artificiality are the adventurous endeavours of Gordon Pask about chiasmic figures and the philosophical speculations of Gotthard Gunther about proemiality, polycontextuality and kenogrammatic. Both are not yet in the focus of academic research.”* Kaehr (Date not set) (Kaehr, 1996)

When the BCL closed, so did much of its advanced research. Thus, one can almost jump from this period to contemporary research, where much of what went on there is part of “An Unfinished Revolution?” (Müller and Müller, 2007) Gunther was interested in Polycontextual logic. Kaehr discusses Gunther at the EMSCR conference in 96:

*“Polycontextual Logic is a many-system logic, a dissemination of logics, in which the classical logic systems (called contextures) are enabled to interplay with each other, resulting in a complexity which is structurally different from the sum of its components. Although introduced historically as an interpretation of many-valued logics, polycontextual logic does not fall into the category of fuzzy or continuous logics or other deviant logics. Polycontextual logics offers new formal concepts such as multi-negational and transjunctional operators... The world has infinitely many logical places, and it is representable by a two-valued system of logic in each of the places, when viewed isolatedly. However, a coexistence, a heterarchy of such places can only be described by the proemial relationship in a polycontextual logical system. We shall call this relation according to Günther the proemial relationship, for it prefaces the difference between relator and relatum of any relationship as such. Thus the proemial*



*relationship provides a deeper foundation of logic and mathematics as an abstract potential from which the classic relations and operations emerge.” (Kaehr, 1996)*

Thus we experience a shift to two new kinds of logic, one, a physical logic, and the second, a conceptual multi-value logic. Given that one of the precursors to the contemporary push toward the creation of an Electrochemical Computer articulated at the Biological Computing Lab, relates to the Storage of Information in Molecules, what von Foerster called Molecular Bionics, (von Foerster, 1963) which included: 1) Storage of Information; 2) Manipulation of Information (computation); 3) Manipulation of Information associated with Energy Transfer. Here we must also remember the work of Conrad, *On designing principles for a molecular computer* (Conrad, 1985) and *Molecular Computing: The Lock-Key Paradigm* (Conrad, 1992) and Pattee, *How Does a Molecule Become a Message?* (Pattee, 1969) and *Discrete and Continuous Processes in Computers and Brains.* (Pattee, 1974)

## 4 Abstracting mind-like behavior into the circuitry of systems at the BCL

Von Foerster also articulated a “Proposal for the Continuation of a Comprehensive Study of the theory and circuitry of systems with Mind-like Behavior”, at the BCL. He describes this thus:

*“The simple aim of this basic research project is to develop the epistemological, conceptual, mathematical, and technological apparatus which is required not only for the construction of systems that achieve goal directed, selective information reduction – or display “mind-like behavior” for short – but also for the derivation of quantitative measures which allow appropriate comparison of the performance of such systems.” (von Foerster, 1963)*

Additionally, at the BCL was the study of how these low level systems “percolate up” as Rössler calls it. Here von Foerster also was researching: “Theory and Application of Computational Principles In Cognitive Systems.” The proposed study included:

*“1) The computational features that map environmental features into percepts; 2) The computational features that map percepts into concepts; and 3) The computational principles that map relations of concepts into linguistic representations... These problems will be approached on three levels: (i) Epistemological: Symbolics; Logic and Axiomatics of Self-referential Systems; Logic of Inferences; Linguistic Heuristics; cybernetics of the large system. (ii) Theoretical: Automata Theory; Computer Software and Relational Networks; Cognitive Network Theory; Compositions and Decompositions of Systems. (iii) Experimental: Technology and Circuitry of Special Purpose Computer Modules and Systems; machine Processing of Visual Images; Electrophysiology of tectal or cortical responses to sensation.” (von Foerster, 1967)*

### 4.1 Other relevant pre-cursors

Neosentience research pre-cursors took multiple forms including:

- Cognitive Memory: An Epistemological Approach to Information Storage and Retrieval — HvF and Robert T. Chien;



- Steps toward a relational structure — F. P. Preparata, K. Kelly and P. Reynolds; and
- Topological Structures of Information Retrieval Systems — R.T. Chien and F.P. Preparata 1966. (von Foerster, 1967)

Another exciting area of research included “Exploring Graph Theory – Documents as nodes and relationships as edges including similarity graphs based on subject-content, and citation graph of linkages of citations by von Foerster. (von Foerster, 1967) This was a pre-cursor for aspects of Seaman’s “Insight Engine”.

A pre-precursor to all of these areas was the text by Kurt Lewin, *Principles of Topological Psychology*. (Lewin, 1936), where multiple kinds of spaces intersected—topological psychological spaces, simulation spaces and physical/actual motion spaces. Here we must also include Pask’s important paper— *The Simulation of Learning and Decision Making Behavior*. (Pask, 1962) Also central is Pask’s “Physical Analogues to the Growth of a Concept”. In: *Mechanisation of Thought Processes*. (Pask, 1958) Yet, how can we come to enfold all of these different foci in the service of Neosentient research?

## 5 The Engine of Engines – Toward a Computational Ecology (Seaman, 2012)

The human being functions as “an ultra-complex time-dependent computational ecology” — A not yet fully entailed ultra-complex bio-machine (this differs from Rosen who does not see the body as a machine). The body functions as an autopoietic unity (Maturana & Varela, 1980) “playing out” these computations of computations (von Foerster, 1981) as an ongoing time-based process.

At this moment it is difficult to parse exactly what computational processes in the body are at operation, and in particular how they contribute to neural computation and the emergent phenomena of sentience. As we learn more about the body’s entailments, we understand the need to examine a series of Biological Computational Languages and how they are interfaced—becoming a language of languages. This includes:

- a. neural transmitters (protein shape communications);
- b. circulating brain wave frequencies – that also function to regulate bodily processes and change synaptic efficacy (Kumar and Mehta 2011);
- c. synapse flows (changing efficacy in part in relation to a. and b. above);
- d. genetic processes contributing to RNA editing (altering the functional properties of neurotransmitter receptors) (Schmauss and Howe, 2002); growth and the formation of the systems themselves (DNA);
- e. Nanoscale processes regulating molecular change and biological communication;
- f. flow processes (acting as analogue computation) or vehicles enabling distributed biological processes;
- g. quantum processes in nanotubules and other locations;
- h. and other biological functionalities still under research (volume transmission) (Agnati et.al., 2010).

Additionally the notion of multi-modal sensing and embodied experience become important mechanisms both in the human and in the production of artificial Polysensing (Seaman’s



coin) environments that might enable a machine to build up knowledge about environment. (Seaman & Verbauwhede, date not set).

In Seaman's paper, *The Engine of Engines, Toward a Computational Ecology* (Seaman, 2012, forthcoming in *Integral Biomathics: Tracing the Road to Reality*, Springer) a series of relevant approaches are discussed. Related to the above list of human/biological computational processes, the research field has spawned many biomimetic and bio-relational computational approaches, including analogue and digital manifestations e.g.

- 1) neuromorphic chips (Folowosele. 2010)
- 2) Protein computers (Mohammed, date not set)(Conrad,1992)
- 3) DNA computers (Karl & Landweber, 1999)
- 4) quantum computers (Hagar 2011)(Markoff 2010)
- 5) embodied sensing systems informing computation/learning systems – polysensing environments (Seaman & Verbauwhede, [date not set])
- 6) analogue flow computers (Pask, 1982)
- 7) analogue physical computers, wind tunnel computers, flow computers (Care, 2006-2007)
- 8) electrochemical computers (Seaman,2004 & 2009) (Sadeghi, 2008) (Sadeghi & Thompson, 2011)
- 9) nano computers and related nano sensors (Parker and Zhou, 2011) (Drexler, 1986) (Drexler, 1992)
- 9) neural nets of differing kinds (Whittle, 2010).

The goal is to form a reciprocal intellectual relation with the Neosentient. This is where benevolence comes in – optimizing toward the other. Thus the reciprocal relation of benevolent behavior always seeks to flow bidirectionally. Here the creation of a creative machine, exploring a meta-field of meta-fields becomes the greatest of transcontextual (Bateson, 1972) endeavors.

## 6 Summary

Cybernetics is the transcontextual science and art of pointing both inwardly and outwardly — relationally. Here, in the service of Neosentient Design, one seeks to abstract abstraction as an ongoing process of ultra-complexity, and articulate a topology of relationalities or better a relationality of relationalities in the service of insight production, technological creativity and ongoing human self-reflection. We seek to build a tool, The “Insight Engine” to help elucidate the actual complexity of currently un-entailed bio-algorithmic processes— the body's natural computational processes and their inter and intra-functionality as a mixed analogue and digital system. Thus we see the future of computing as being both bio-mimetic and bio-relational, mixing both analogue and digital processes.\* Yet, we are now only at the infancy of creating such a computational system. It is clear that a series of cybernetic precursors were at play in the development of neosentience research, in particular, studies leading to a deep understanding of the Abstraction of Abstraction.

### References

- Agnatia, L., Guidolinb, D., Guescinic, M., Genedania, S., & Fuxe, K. (2010) Understanding wiring and volume transmission. *Brain Research Reviews* Volume 64, Issue 1, September 2010, Pages 137–159. <http://www.sciencedirect.com/science/article/pii/S0165017310000214> (Accessed 16, April, 2012)



- Bateson, G. (1972). *Steps to an Ecology of Mind*. New York: Ballantine Books, pp. 271–73.
- Care, C. (2006-2007). A Chronology of Analogue Computing, *The Rutherford Journal*. Volume 2, 2006-2007. <http://www.rutherfordjournal.org/article020106.html> (Accessed 16 April, 2012)
- Conrad, M. (1985). On designing principles for a molecular computer. *Comm. of the ACM*, 28:464–480, 1985.
- Conrad, M. (1992) *Molecular Computing: The Lock-Key Paradigm*, *Computer*, vol. 25, no. 11, pp. 11-20, Nov. 1992, doi:10.1109/2.166400
- Drexler, E. (1986) *Engines of Creation*. Anchor Books
- Drexler, E. (1992) *Nanosystems: Molecular Machinery, Manufacturing, and Computation*. In particular, see Chapter 12, *Nanomechanical Computational Systems*,
- Foerster, H. von (1963). Proposal for the Continuation of a Comprehensive Study of the theory and circuitry of systems with Mind-like Behavior, *Archives of BCL, University of Illinois*
- Foerster, H. von (1965). *Bionics Principles*, in: *Bionics*, R. A. Willaume (Hg.), AGARD, Paris, S. 1-11, 1965.
- Schlagwort: Bionik/Molekularbiologie.
- Foerster, H. von (1967) *Theory and Application of Computational Principles In Cognitive Systems*, *Archives of BCL, University of Illinois*
- Foerster, H. von (1981). *Observing Systems*. Intersystems Publications
- Foerster, H. von (1974). *Cybernetics of Cybernetics [book]* (Originally published by Heinz von Foerster and the Biological Computer Laboratory at the University of Illinois). See also Brun, H. and Sloan, S. (1995). *Cybernetics of Cybernetics*. Future Systems Inc.
- Foerster, H. von (1995). *Cybernetics and circularity, anthology of principles propositions theorems...* May 17–21, 18–19. Available from: <http://www.cybsoc.org/heniz.htm>. [Accessed 15 April 2012].
- Foerster, H. von (2003). *Understanding Understanding*. New York: Springer
- Foerster, H. von and Poerksen, B. (2002) *Understanding systems: conversations on epistemology and ethics*. K. Leube, trans New York, Boston, Dordrecht, London, Moscow: Kluwer Academic/Plenum.
- Folowosele, F. (2010) *Neuromorphic Systems: Silicon neurons and neural arrays for emulating the nervous system*. From <http://www.neurdon.com/2010/08/12/neuromorphic-systems-silicon-neurons-and-neural-arrays-for-emulating-the-nervous-system/> (Accessed 15, April, 2011)
- Gaugusch, A. and Seaman, B. (2004). (RE)sensing the Observer, Offering an Open Order *Cybernetics, Technoetic Arts: A Journal of Speculative Research* Volume 2 Number 1. © Intellect Ltd 2004.
- Givón, T. (1989). *Mind, Code and Context: Essays in Pragmatics*. London: Lawrence Erlbaum Associates.
- Glanville, R. (2007) *Designing Complexity*, *Performance Improvement Quarterly* 20 (2) pp75-96
- Glanville, R. (2011). *To Be Decided*, in *Cybernetics and Human Knowing*. Vol. 18, nos. 3-4, pp. 101-110
- Glanville, R. (2012). *Notes for Symposium E. Cybernetics of ...: Reciprocity and Reflexivity in Cybernetic Thinking*. <http://www.emcsr.net/symposium-e-cybernetics-of-...-reciprocity-in-cybernetic-thinking/> (Accessed 1, April, 2012)
- Gunther, G. (Gunther, 1962) *Proposal For a Basic Study of the Semantic and Syntactic Properties of Many-Valued and Morphogrammatic Systems of Logic*. 1962, *Biological Computer Lab Archive*, Champaign/Urbana, Illinois, Illinois State University.
- Hagar, A. (2011) *Quantum Computing*, in the *Stanford Encyclopedia of Philosophy*. <http://plato.stanford.edu/entries/qt-quantcomp/> (Accessed 15 April, 2012)
- Kaehr, R. (date not set), *Morphogrammatics And Computational Reflection*. <http://memristors.memristics.com/MorphoReflection/Morphogrammatics%20of%20Reflection.html>
- Kaehr, R. (1996) *Introducing and Modeling Polycontextural Logics*, presented at the EMCSR '96 conference. <http://www.thinkartlab.com/pkl/emscr96.htm> (accessed 23 April, 2012)
- Kari, L. and Landweber, L. F. (1999). *Computing with DNA*. *Methods in Molecular Biology*.
- Koestler, A. (1964). *The Act of Creation*. New York: Macmillian Co.
- Kumar, A. and Mehta, M. (2011). *Frequency-Dependent Changes in NMDAR-Dependent Synaptic Plasticity*. *Front Comput Neurosci*. 2011; 5: 38.also <http://www.ncbi.nlm.nih.gov/pmc/articles/PMC3182344/> (Accessed 16, April 2012)
- Levine, D. (2009). *Continuous and Random Net Approaches in Introduction to Neural and Cognitive Modeling*. Lawrence Erlbaum and Associates (2nd edition)





- Lewin, K. (1936). *Principles of Topological Psychology*. New York: McGraw-Hill.
- Markoff, J. (2010). Quantum Computing Reaches for True Power. *The New York Times*.  
<http://www.nytimes.com/2010/11/09/science/09compute.html> (Accessed 16 April, 2012)
- Maturana, H. and Varela, F. (1980). *Autopoiesis and Cognition: The Realization of the Living* (Boston Studies in the Philosophy of Science, Vol. 42)
- Mohammed, R. (date not set) *Molecular and Biomolecular Electronics*.  
[http://www.scribd.com/pradeep\\_p\\_16/d/61676225-Protein-Based-Dna-Computers](http://www.scribd.com/pradeep_p_16/d/61676225-Protein-Based-Dna-Computers) (Accessed 15 April, 2012)
- Nadine, M. (2010) Anticipation and dynamics: Rosen's anticipation in the perspective of time, *International Journal of General Systems*, 39: 1, 3 — 33
- Müller, A. (1995). From Second Order Cybernetics to Second Order Science, Keynote address, Annual Conference of the American Society for Cybernetics,  
[www.gwu.edu/~rpsol/ASC/Slides/muller01.ppt](http://www.gwu.edu/~rpsol/ASC/Slides/muller01.ppt) (Accessed 13, February, 2012)
- Müller, A. (2000). A Brief History of the BCL. Heinz von Foerster and the Biological computer Laboratory. <http://bcl.ece.illinois.edu/mueller/index.htm> (Accessed 13, February, 2012)
- Müller, A. and Müller, K. (2007). An Unfinished Revolution? Heinz von Foerster and the Biological Computer Laboratory | BCL 1958-1976, Edition Echoraum
- Parker, A. and Zhou, C. (2011) proceedings of the IEEE/NIH 2011 Life Science Systems and Applications Workshop in April 2011, as discussed in the article Functioning Synapse Created Using Carbon Nanotubes. <http://neurosciencenews.com/synapse-using-carbon-nanotubes-synthetic-brain/> (Accessed 16 April, 2012)
- Pask, G. (1961). *An Approach to Cybernetics*, MIT Press, Cambridge
- Pask, G. (1958). Physical Analogues to the Growth of a Concept, in *Mechanisation of Thought Processes*, Proceedings of symposium held in the national physical Laboratory, on 24-27 November, Volume II National Physical Laboratory Symposium #10. London: Her majesty's Stationery Office, 1959
- Pask, G. (1962). *The Simulation of Learning and Decision Making Behavior*.  
Pask, G. and Curran, S. (1982) *Microman: Computers and the Evolution of Consciousness*. New York: Macmillan.
- Pattee, H. (1969) How Does a Molecule Become a Message?. *Developmental Biology Supplement*, 3: 1-16.
- Pattee, H. (1974) Discrete and Continuous Processes in Computers and Brains. In M. Conrad, W. Güttinger & M. DalCin (eds.) *The Physics and Mathematics of the Nervous System*, New York: Springer, pp.128-148.
- Perriquet, O. and Seaman, W. (2011). Art ↔ Science Relationalities. *International Symposium on Electronic Art Proceedings* (forthcoming)
- Pickering A. (2010). *The Cybernetic Brain: Sketches of Another Future*. Chicago: Chicago
- Rashevsky, N. (1933) Outline of a Physico-mathematical Theory of Excitation and Inhibition, *PROTOPLASMA*, Volume 20, Number 1, 42-56
- Rosen, R. (1985) *Anticipatory systems. Philosophical, Mathematical and Methodological Foundations*. New York: Pergamon Press.
- Sadeghy, S. (2008). *Design of an Electrochemical Cognitive System - A study and application of emergent spatio-temporal patterns in far from equilibrium nonlinear systems*. PhD Thesis, Department of Chemistry, University of Toronto
- Sadeghy, S., and Thompson, M. (2011) Towards information processing from nonlinear physical chemistry: A synthetic electrochemical cognitive system. *BioSystems* 102 (2010) 99–111
- Seaman, B. and Rössler, O. E. (2011). *Neosentience | The Benevolence Engine*. London: Intellect Press
- Seaman, B. (2005) "Pattern Flows | Hybrid Accretive Processes Informing Identity Construction." *Convergence Magazin* 7.2, special Issue on Intelligent Environments.
- Seaman, B (2008). Unpacking Simultaneity for Differing Observer Perspectives and Qualities of Environment in Simultaneity – Temporal Structures and Observer Perspectives, edited by Vrobel, Rössler, and Marks-Tarlow, World Scientific
- Seaman, B (2010). *Recombinant Poetics / Emergent Meaning as Examined and Explored Within a Specific Generative Virtual Environment*. VDM Press, Germany
- Seaman, B. (2010) (Re)Thinking — The Body, Generative Tools and Computational Articulation. *Technoetic Arts*



- Seaman, B. (2012). The Engine of Engines - Toward A Computational Ecology, in *Integral Biomathics: Tracing the Road to Reality - Proceedings of ACIB'11 Conference in Stirling, Scotland, August 29-31, 2011 and iBioMath'2011 Workshop at ECAL'11, Paris*, edited by P. L. Simeonov, L. S. Smith, A. C. Ehresmann (Eds.). (Winter, 2011), Springer-Verlag, Berlin-Heidelberg
- Schmauss, C. and Howe, J. R. (2002). RNA Editing of Neurotransmitter Receptors in the Mammalian Brain. *Sci. STKE*, 21 May 2002 Vol. 2002, Issue 133, p. 26.  
<http://stke.sciencemag.org/cgi/content/abstract/sigtrans;2002/133/pe26>  
(Accessed 16 April, 2012)
- Stanford Encyclopaedia of Philosophy, 'Turing Test' <http://plato.stanford.edu/entries/turingtest/>.  
Accessed 13 February 2012.
- Turing, A. (1950), *Computing Machines and Intelligence*, in John Haugeland (ed.), *Mind Design II: Philosophy, Psychology, Artificial Intelligence*, Cambridge: MIT Press, 1997. See also Turing, *Mechanical Intelligence*, D. C. Ince (ed.), New York.
- von Neumann, J. (1948). *The General and Logical Theory of Automata*
- von Neumann, J. (1995), *The Neumann Compendium*, vol. 1, F. Bródy and T. Vámos (eds), Singapore: World Scientific Publishing, pp. 526–28.
- von Neumann, J. (1995), *The Neumann Compendium*, vol. 1, F. Bródy and T. Vámos (eds), Singapore: World Scientific Publishing pp534-35
- Zhuravlev, Yu. I. and Gurevich, I. B. (2010) Sixty years of cybernetics in *Pattern Recognition and Image Analysis*, March 2010, Volume 20, Issue 1, pp1-20

## About the Author

Bill Seaman

Seaman's artwork often explores an expanded media-oriented poetics through various technological means. More recently he has been exploring notions surrounding "Recombinant Informatics" — a multi-perspective approach to inventive knowledge production. He has been commissioned on a number of occasions. He is currently working on a series of art/science collaborations — poetic installations and scientific research papers. The book *Neosentience | The Benevolence Engine* with Otto Rössler has recently come out through Intellect Press. He is also collaborating with artist/computer scientist Daniel Howe on multiple works exploring AI and creative writing/multi-media and has completed an album of experimental music with Howe entitled *Minor Distance*. He is developing a new VR work and undertaking interface research with Todd Berreth; is exploring the creation of a transdisciplinary research tool — *The Insight Engine*; and is collaborating with John Supko on a new generative audio work. He has also recently completed a major new album project with Craig Tattersall – *Light Folds*.